



CM Introduces New CM2R Liberator

For Immediate Release: May 27, 2010 - Columbus McKinnon Corporation, Sarasota, Florida is pleased to announce the latest product development. The newly designed CM2R Liberator. (2 Rotor) Due to the enormous success in the Industry from the larger CM4R Liberator, a new, smaller, more affordable version has been created by CM.

Similar to the larger version, the CM2R Liberator's unique design allows it to separate the wire from rubber tires in the purest, cleanest form possible, allowing processors to generate revenue streams from both rubber and wire.

Operational benefits include:

- Increased product yield
- Multiple opportunities for profit
- Highest production rates
- Opportunity for diversification

Its serrated knife design increases linear inches of cut, which means more cutting surface. The larger screen area allows efficient screening of sized material. These two factors are critical in allowing the CM Liberator™ to achieve greater production.

Along with increased production comes increased wear. The CM Liberator™ addresses this situation with its exclusive "Armor-Plated" rotor and rotor housing, which dramatically reduces wear to internal components. The internal wear surfaces are lined with replaceable wear liners that are easily changed when worn. This exclusive feature of the CM Liberator™ eliminates the need for any maintenance welding and results in greater machine "uptime".

Combine all these features with our exclusive patented process "flow-through" design that reduces pinch points and allows steel to purge through the process, and you have one of the most profitable tire wire liberating systems available.

Depending on screen size the system is capable of processing passenger car and truck tire material at production rates ranging from 2000 to 10,000 lbs. per hour. The Liberator is capable of producing wire free ground rubber, and clean steel to be sold into higher value added markets.

For additional information on CM Tire Recycling Equipment and Systems please contact us at our new site at www.cmtirerecyclingequipment.com. This is an interactive site where you can review system layouts and as well as see the equipment in operation. You may also contact Kaytee Moran at Kaytee.Moran@cmworks.com (941) 755.2621 ext 29.

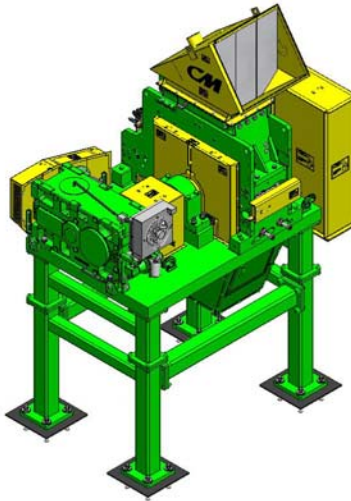

The New CM2R Liberator Developed at CM Sarasota Operations, FL Manufacturing Facility.

CM[®] Tire Recycling Equipment Solutions

Columbus McKinnon Corp.
1920 Whitfield Avenue Sarasota, FL 34243
(941) 755-2621 Toll Free 1(800) 848-1071
www.cmtirerecyclingequipment.com